

Addressing Challenges Of Sterile Ophthalmic Product Filling



Authors:

John Erdner

Portfolio Manager for Fill-Finish, SP Industries

Alex Armengol

International Senior Sales director, SP i-Dositecno

Abstract

Many innovative pharmaceutical packaging formats are being developed to meet the growing requirement for sterile, safe and secure packaging and delivery of ophthalmic products. Due to the diversity of these sterile ophthalmic medications, aseptic filling lines must be highly sophisticated and adaptable to address a variety of packaging challenges in this growing market.

Unquestionably, the eyes are one of the most important and highly sensitive organs in the human body. The slightest irritation can cause extreme discomfort and lead to infections, swelling, and allergies. Vision may also be affected, possibly resulting in permanent damage and blindness. Therefore, sterile packaging of pharmaceutical products for ophthalmology applications is crucial, with absolutely no margin for error during the packaging process.

The eye drops market is segmented into the categories of eye diseases, eye care and others. The ophthalmic/eyecare industry is growing rapidly, with a projected CAGR (compound annual growth rate) of 5.1% from 2019 to 2026, by which time it is projected to reach \$1.95 billion. North America dominates the global vision care market, while Europe is growing quickly, and Asia-Pacific is an emerging market. Much of this growth is due to the increase in the geriatric segment of the market where deteriorating eyesight is common.

An increasing awareness of preventative care for vision loss and the wider variety of surgical solutions, along with new topically administered drug developments to treat ophthalmic diseases and eye disorders, will dramatically increase the size of the global vision care market.

Historical Overview

Many ophthalmic diseases and eye irritations are treated with topically administered drug products. However, whereas early production environments were unclassified, the ophthalmic industry has changed dramatically over the years, and these operations now fall under regulatory scrutiny, so filling operations must be accomplished in cleanrooms with controlled environments.

Historically, ophthalmic packaging included a glass vial with a separate dropper, however because the reintroduction of the dropper into the product when dispensing presented a contamination risk, the industry moved to plastic containers with a combined drip tip. These greatly improved containment of the sterile solution and minimized the risk of user contamination and have several advantages when compared to glass containers in that they are unbreakable, compressible and light. There are also different plastic options, with differing features which must be considered as these can present challenges when filling product. For example, polypropylene containers provide better barrier protection, as they can tolerate terminal sterilization, but are rigid and difficult to squeeze.

Alternative polyethylene components are soft and squeezable but cannot withstand terminal sterilization and need to be pre-sterilized, meaning that the entire filling process for these bottles must be completely sterile. Furthermore, polyethylene is permeable and can absorb active ingredients as well as preservatives while permitting the ingress of oxygen which degrades some products. Therefore, stability studies must be performed with each specific product and container combination to balance the desired functionality with shelf life.

Today more than 70% of the ophthalmic drug products are simple solutions supplied in multi-dose plastic container closure systems (CCS) which generally contain a month or longer supply of the drug. Preservatives such as Benzalkonium Chloride help to extend the life of the product, but recently observed side effects have created the market for preservative-free alternatives. Consequently, many innovative and new pharmaceutical packaging formats are being developed and introduced regularly to meet the growing requirement for sterile, safe and secure packaging and delivery of ophthalmic products.

Regulatory Requirements

Ophthalmic drug packaging components are regulated by the FDA's Centre for Drug Evaluation and Research (CDER). These components function together to: protect the quality of the drug product; maintain product sterility following initial seal breakage by the patient; aid dosing and administration; and minimize product contamination throughout its use. Due to the extended period of use, ophthalmic drug product packaging is considered more crucial to product performance and safety than the packaging used for solid oral drug dosage forms.

The appropriate system of quality assurance for the manufacture of ophthalmic pharmaceutical products should therefore follow the WHO guidelines for good manufacturing practices (GMP). The requirements for pharmaceutical packaging and packaging materials - as described in compendia (pharmacopoeias) and standards, eg those of the International Organization for Standardization (ISO) - must be considered only as general in character. The suitability of packaging or packaging material for any particular requirements and conditions can only be ascertained through detailed packaging and stability studies on the product concerned.

Quality Components Are Key

The quality of ophthalmic pharmaceutical product packaging therefore plays a very important role in the overall quality of the product. It must:

- Protect against all adverse external influences that can alter the properties of the product, eg moisture, light, oxygen and temperature variations
- Protect against biological contamination
- Protect against physical damage
- Carry the correct information and identification

The standard multiple-dose CCS for liquid ophthalmic drug products consists of a 3-piece eyedrop container comprised of a bottle (squeezeable plastic container), a drug-dispensing



Figure 1: Traditional 3-piece eyedrop containers

tip/dropper and cap (Figure 1). Optionally, over seals or other tamper-evident features are commonly incorporated.

A more recent development has been the 2-piece eye drop for preservative-free products (Figure 2). This container and cap dispenser is gaining market acceptance as it eliminates the need for preservatives, which may have negative effects on patients. Once the cap has been opened, the product is dispensed through a 0.2-micron filter which prevents backflow of bacteria. The container sidewalls are extremely soft and so special consideration is required to support the neck of the vial during cap closure.



Figure 2: Newer 2-piece eye drop container for preservative-free products

The filling requirements for both types of containers present unique challenges depending on the product being packaged, that must be accommodated within the sterile filling line.

Addressing Filling Challenges

Since ophthalmic pharmaceutical product packaging can present several challenges during the filling process, the system used for filling and capping must be specifically designed to address these challenges.

One such system is the MI-O, specially developed by SP i-Dositecno to handle these extremely small and light plastic eye drop containers, in a variety of formats, including preservative-free, aero pump and standard drop caps. The MI-O efficiently orients, fills, places the drip tip and applies the threaded cap, all at high speeds and in a sterile environment. Within its linear layout, the MI-O houses a number of key components which make it fully adaptable to the specific characteristics of each individual ophthalmic product, enabling the efficient packaging of eye drops in a range of formats, including preservative-free, aero pump and standard drop caps. The first key challenge that a system such as the MI-O must address is the fact that the smaller plastic containers are light with a relatively high center of gravity, meaning that they can topple over easily during the filling

process. Therefore, vacuum belts may be required as an option to maintain an upright position during the linear transfer process. These plastic containers must be positively controlled from the beginning of the filling process at the unscrambler through to final cap closure.

Key Filling System Components

Unscrambler

As all the plastic containers come in bulk, they must be oriented. Slower speed applications (less than 100 vials per minute) can be handled using vibratory sorting bowls, and this type of unscrambler is used in the MI-O, which can handle up to 6000 vials per hour (Figure 3 a & b). This solution is easily sanitized and good for cleanroom applications with laminar airflow. In addition, all parts of the equipment are reachable through the Restricted Access Barrier system (RABs) enclosure with gloves.

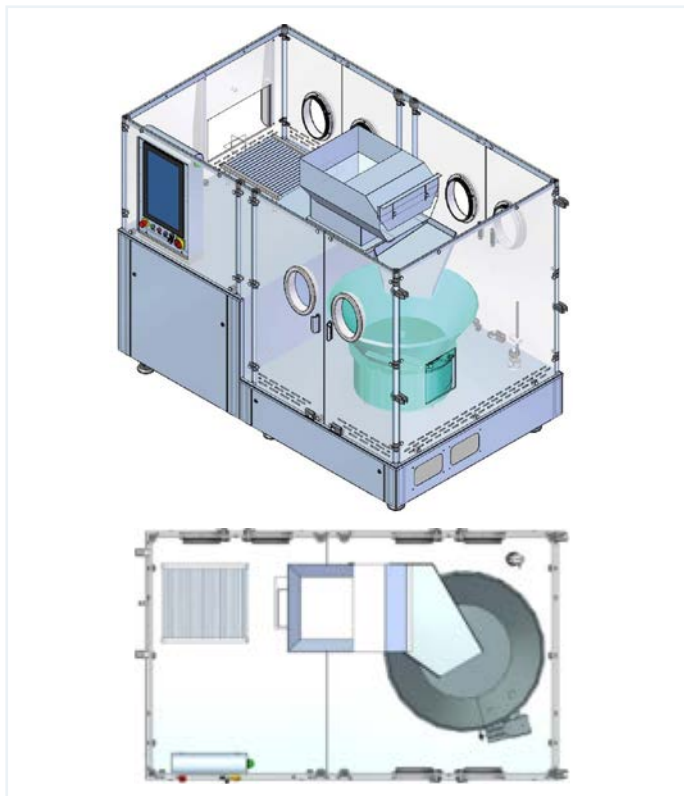

Figure 3 a & b: A vibratory unscrambler used by the MI-O ensures easy sterile sorting of plastic containers

For higher speed applications (up to 200 vials per minute), a mechanical unscrambler is typically used (Figure 4). These units are generally larger and more challenging to access through RABs enclosures. The mechanical movements of the unscrambler generate particles, and air jets are commonly used to help move the vials, this may also introduce contamination. The mechanical

unscrambler is difficult to clean and sanitize as it is harder to reach all parts of the machine with RABs enclosures. Therefore, this methodology is not ideal from a GMP perspective, but that is often overlooked in order to obtain the higher throughput.

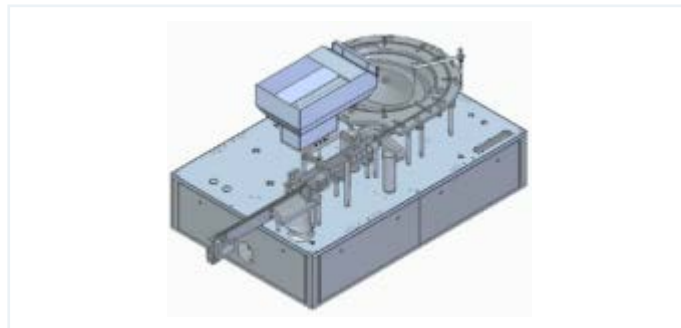

Figure 4: A mechanical unscrambler used for higher speed filling can prove challenging to clean

Filling

Key requirements for a filler are that it must be designed to GMP standards and accommodate unobstructed laminar airflow over the vial path with minimal shadowing. The machine should be linear so that all areas can be accessed through RABs gloves for cleaning and sanitization. The SP i-Dositecno MI-O filling and capping machine has been specifically designed to overcome a variety of such filling challenges, and as ophthalmic product characteristics vary greatly, it is important to have this flexibility built into the filler so that it can handle many different filling requirements.

Options can include peristaltic pumps, which - although not quite as accurate as positive displacement pumps for small volumes - use rollers to squeeze a charge of fluid through a tube, and once a batch is finished the tubing can be disposed, so there is no need for a validated cleaning procedure. Some customers prefer a peristaltic pump to accommodate a single use disposable product path.

Alternatively, two-piece ceramic piston pumps provide higher filling accuracy and cleaning-in-place/sterilization-in-place (CIP/SIP) capabilities. The piston within a cylinder moves up and down to withdraw fluid from the tank and then dispense a specific volume into the vial. The piston has a slot on the side and rotates from the inlet to the outlet which acts as a valve, as well as the cylinder for volume displacement. This type of system does need to be cleaned and sterilized between batches.

Some ophthalmic products are very expensive, and it is important to include 100% in-process control of the filling weight, and to provide a net weight solution during start up and end of batch, to minimize product loss. Certain product families have

suspensions which require continuous mixing of the product and a subroutine to keep the product moving during machine stops in order to prevent precipitation. Options to overcome these issues include the use of recirculation and magnetic mixer technology. In addition, some products oxidize quickly and so require nitrogen purging before, during, and after filling to reduce the residual oxygen content within the container headspace.

Dropper Tip Insertion

Dropper tips come in various sizes and need a reliable system to orient them properly so they can be picked up and accurately placed within the neck of the bottle. The vertical force needed for the final tip placement can also vary depending on the designed tolerances between the tip and bottle.

Some bottles have very thin walls for squeeze ability, which will collapse during the tip placement process unless the bottle neck is supported properly by the filling and capping system. For example, two-piece eyedrop packaging for preservative-free products is highly susceptible to collapse and must be supported very carefully to prevent issues. The MI-O achieves this by using a specially designed pick and place system (Figure 5).



Figure 5. The two-piece eyedrop package for preservative free products is very susceptible to collapse and must be supported carefully to prevent issues

Cap Insertion

Domed caps must also be handled very accurately, similarly to the dropper tips by using a pick and place system. Components are fed into a supply hopper that feeds a vibratory bowl on demand. The vibratory bowl will orient the caps to flow down a chute to a pick and place station where they will be picked up by vacuum and accurately placed onto the top of the container and tip. Some bottle designs have a recessed thread which also requires the pick and place station to rotate and initiate thread engagement. This will prevent cross-threading in the final torque station.

Cap Closing

The final station on the ophthalmic product filler line captures the cap and rotates the threaded component to ensure the container has been fully sealed. Precise application torque is important as plastic threads will relax over time and it is essential that a container remains fully sealed throughout its shelf life. This torqueing station is servo driven and so the pre-established closing torque level will be consistently met.

Some advanced filling machines, such as SP i-Dositecno's MI-O, also offer a torque meter system option to monitor and record 100% of the application torques (Figure 6). This is accomplished using strain gauge instruments to directly measure the resistance torque of the container; the data can then be used to readjust application torque settings as necessary.

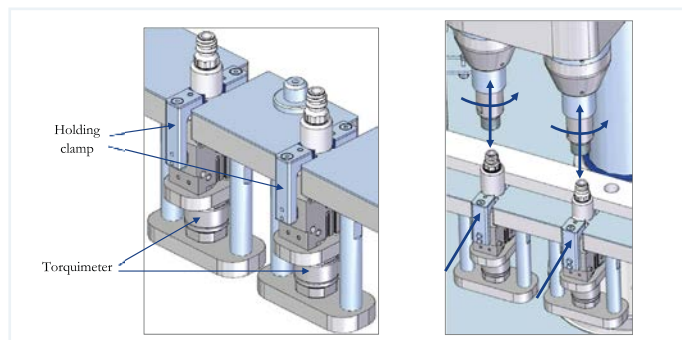

Figure 6: Sophisticated filling machines such as the MI-O can offer a screw torque monitoring system using strain gauges to provide application torque data for all products

Conclusion

The ophthalmic market is growing rapidly due to an increasingly aging population and advancements in cures for previously untreatable conditions. Because the applications and formats of ophthalmic pharmaceutical products are diverse, filling lines need to be highly sophisticated to handle the wide variety of requirements, and advancements must keep pace with market demands.

Having recognized the very specific needs of the ophthalmic market for advanced, flexible and reliable filling systems as far back as 2005, SP i-Dositecno is very well placed to meet these technological challenges with its MI-O filling equipment, which has been specially designed for ophthalmic products. The company has continually evolved its advanced filling lines to accommodate the needs of the new pharmaceutical packaging formats. With this constant innovation, SP i-Dositecno can fully support the growing global requirement for sterile, safe and secure packaging and delivery of ophthalmic products.